



Triple Beam

3D Polarization Modulator

YT-PS500

for Cinema projector



Basic principles

Illustrated linearly polarized light: Multiple directions of light (right). After pass through a linear polarizer, leaving only the light in the same direction as the polarizer polarities (left).

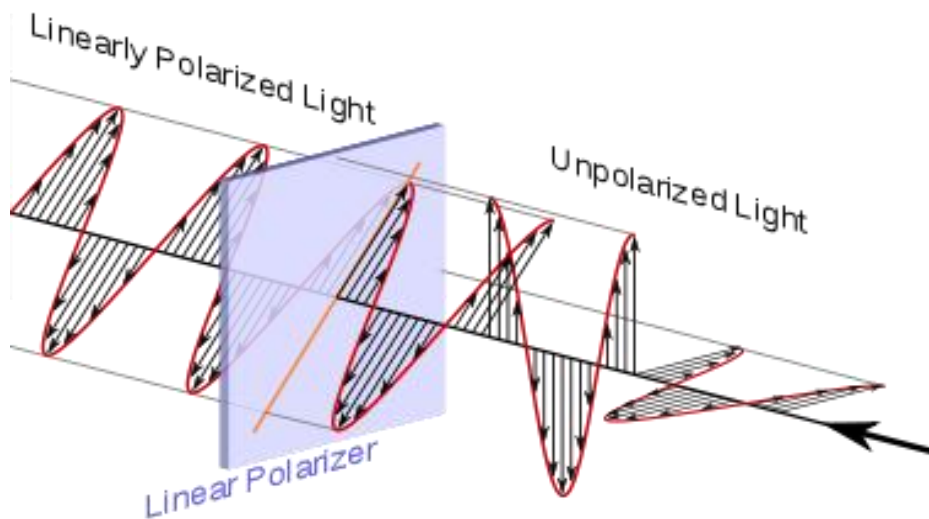

Illustrated circularly polarized light: Lights in multiple vibration directions (right) pass through a linear polarizer and become linearly polarized light (middle), and then pass through the waveplate to become circularly polarized light (left).

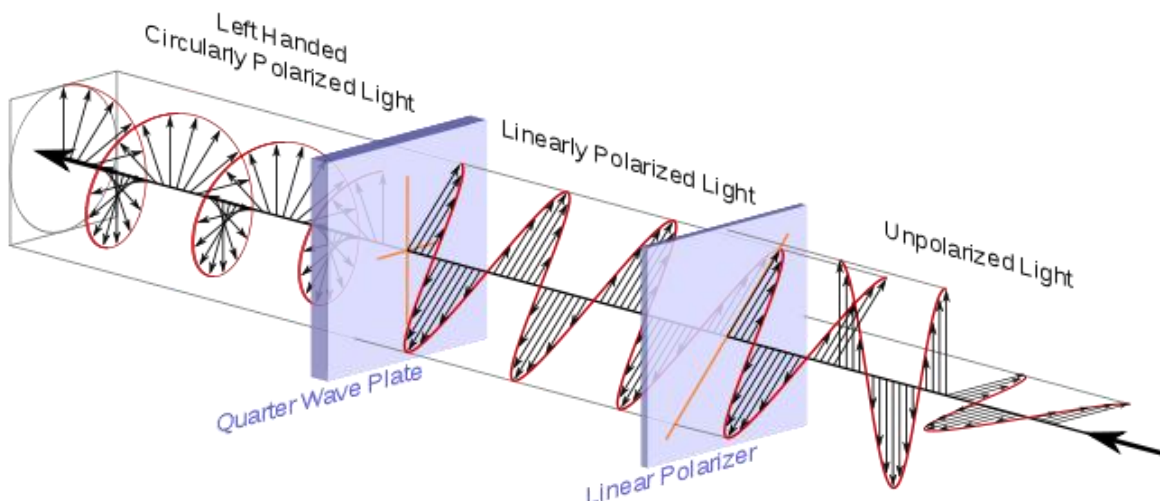

[Learn more\(video\).....](#)

YANTOK YT-PS500 is a high-efficiency triple beam 3D polarization modulator designed for luxury digital cinemas, large-format 3D screening rooms, and professional engineering venues that require superior light efficiency and flexible installation. Built with advanced triple optical path technology, this model delivers approximately twice the light efficiency of standard single-beam 3D polarization systems, greatly reducing brightness loss from the projector and ensuring brighter, sharper, and more vivid 3D images on the big screen.

Compared with dual-beam 3D systems, the triple-beam design splits the secondary light path into two independent optical channels, allowing it to work with projectors with much smaller throw ratios-down to an exceptional 1.0:1- making it ideal for cinemas and venues with limited installation space or short projection distances. It is fully compatible with universal MasterImage and RealD format passive circular polarized 3D glasses, so cinemas and venues can continue using their existing eyewear inventory while upgrading to a higher-performance 3D solution

Based on industry-standard circular polarization technology- the most widely used passive 3D technology in commercial cinemas, 3D theaters, and polarized 3D displays worldwide-YT-PS500 provides stable, high-quality 3D performance with low ghosting, high contrast, and natural color reproduction. It supports major professional cinema projector brands including Christie, NEC, and Barco, with automatic 2D/3D switching via TMS (Theatre Management System) for smooth, intelligent operation. With a wide operating temperature range of 0–60°C and heavy-duty construction, YT-PS500 ensures reliable long-term performance in high-intensity cinema environments.

Applications

YANTOK YT-PS500 is specially designed for high-end professional 3D environments:

- ※Luxury digital cinemas and premium commercial movie theaters
- ※Large-scale 3D projection engineering venues
- ※High-brightness large-screen cinema auditoriums
- ※Venues with limited space and ultra-low throw ratio requirements
- ※Professional cinema chain upgrade and renovation projects
- ※Exhibition halls, science museums, and immersive theater spaces



✔ Triple-Beam Design for Ultra-High Light Efficiency

YT-PS500 uses a professional triple optical path structure that provides approximately 2x higher light efficiency than standard single-beam 3D polarization modulators. This greatly reduces projector brightness loss, delivering brighter, clearer, and more vibrant 3D images for premium viewing experiences.

✔ Supports Ultra-Low Throw Ratio Down to 1.0:1

By splitting the secondary light path into two separate channels, the triple-beam system supports much smaller throw ratios than dual-beam systems. It can work with projectors at $>1.2:1$ or as low as $1.0:1$, making it perfect for venues with limited space or short projection distances.

✔ Circular Polarization Technology (Passive 3D)

Adopts reliable circular polarized optical technology — the most popular and cost-effective passive 3D solution for global cinemas, commercial theaters, 4D/5D dynamic venues, and large-scale 3D display systems.

✔ Universal Compatibility with RealD & MasterImage Glasses

Fully compatible with standard RealD and MasterImage passive circular polarized 3D glasses used in cinemas worldwide. Venues can reuse existing low-cost eyewear without additional investment, lowering long-term operating costs.

✔ Ultra-High Transmittance & Optical Efficiency

Features an outstanding light transmittance of $78\% \pm 2.5\%$ and optical efficiency of $32\% \pm 2\%$, ensuring maximum brightness output and minimal light loss for large-screen 3D projection.

✔ Ultra-Low Ghosting & High Visual Clarity

Ghosting rate controlled below 1.3%, delivering clean, immersive, and professional 3D visuals with minimal crosstalk and excellent depth performance.

✔ **Fast Optical Response & High Frame Rate Support**

Ultra-fast response time of <math><150\mu\text{s}</math> and support for frame rates above 600Hz, ensuring smooth, stable, and artifact-free 3D playback for high-speed content.

✔ **Automatic 2D/3D Switching via TMS**

Supports fully automatic 2D/3D conversion through the theater TMS system, enabling intelligent, operator-free mode switching for daily cinema operations.

✔ **Wide Compatibility with Top Cinema Projectors**

Officially supports leading professional cinema projector brands: Christie, NEC, Barco. Works with standard sync interfaces including DB37, DB15, and BNC for seamless integration.

✔ **Strict Optical Specifications for Professional Cinemas**

Designed for screen gain between 2.0–3.0 (recommended 2.5) and minimum polarization contrast of >150:1, ensuring consistent, high-quality 3D performance on professional metal screens.

✔ **High Brightness Support & Stable Performance**

Supports projectors up to 50,000 lumens and operates reliably in temperatures from 0°C to 60°C, making it suitable for continuous use in large commercial cinemas and high-end screening venues.

Technical Specifications

1. Optical Glass Effective Area: Input window: 135mm x 70mm
2. Light Transmittance: 78% \pm 2.5%
3. Optical Efficiency: 32% \pm 2%
4. Ghosting Rate: < 1.3%
5. Optical Principle: Circular polarization
6. Response Time: < 150 μ s
7. Supported Frame Rate: to 600Hz
8. 2D/3D Conversion: Automatic TMS
9. Supported Screen Gain: 2.0 – 3.0 (recommended 2.5)
10. Required Metal Screen Polarization Contrast: > 150:1
11. Supported Interfaces: DB37 / DB15 / BNC
- 12. Supported Throw Ratio: >1.2:1 or 1.0:1**
- 13. Minimum Throw Distance: 8M or 10M**
14. Supported Projector Brands: Christie, NEC, Barco
15. Max Supported Projector Brightness: 50000 Lumens
16. Operating Temperature: 0°C – 60°C
17. Total Gross Weight (2 boxes): Approx. 30KG

Packing Instructions

Please carefully check the contents of the carton and keep the receipts, packing boxes and packaging foam. If the product is damaged during transportation, please contact us for replacement.

Optical Unit Carton includes :



1.3D Modulator

2. UserManual(PDF)

Bracket Cartosn includes:

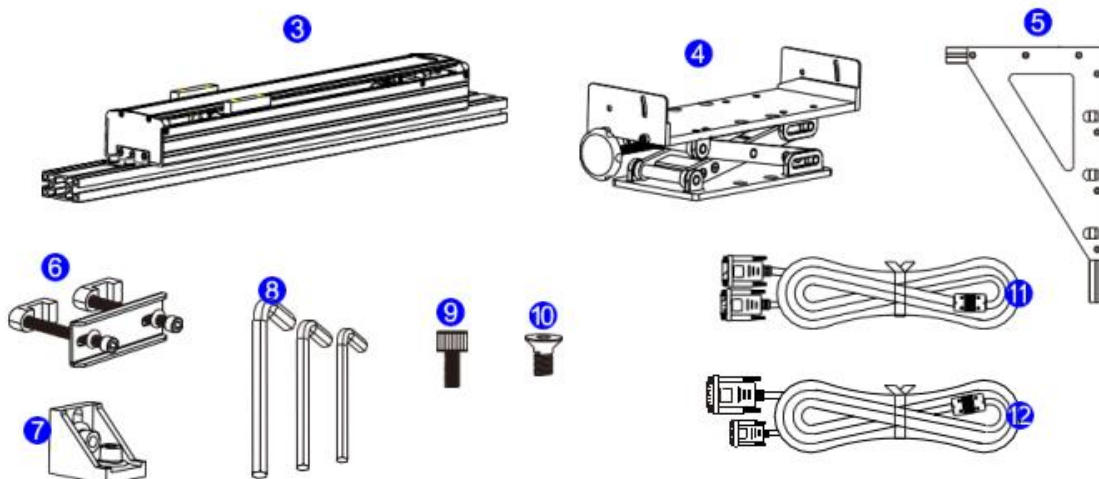

3.Motor slide rails×1PC

4.Lifting Mechanism×1PC

5.Triangular Bracket × 2PCS

6.Installing Buckle Assembly×4PCS

7.Corner Code ×2PCS

8.M5, M4, M3 Allen Wrench ×1PC

9.M5×12mm Cylindrical Body
Hexagon Screw ×4PCS

10.M5×12mm Countersunk Head
Hex Head Screw ×4PCS

11.DB9M/9F Motor Drive Cable×1PC

12.DB15M/9F Sync Signal Cable×1PC

Installation Examples

After loosening the screw, you can adjust the tilt angle of the optical part. When adjusting, pay attention to controlling the polarization modulator to avoid hitting the projector lens. Please lock the screw after adjustment.

Height Adjustment Handle

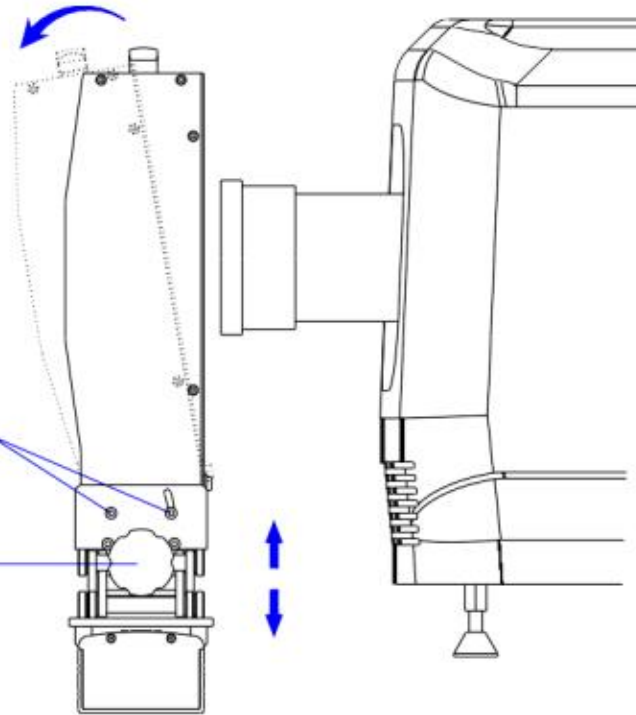

When adjusting the height of the optical part, pay attention to the size of the upper and lower beam, as shown below:

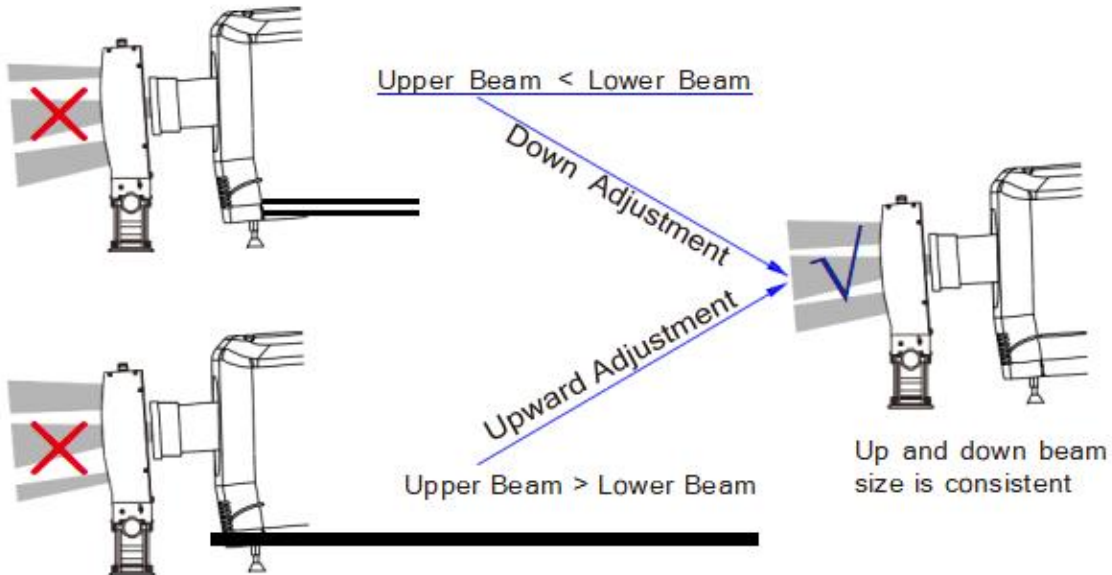

Align the three light beams so they overlap on the screen

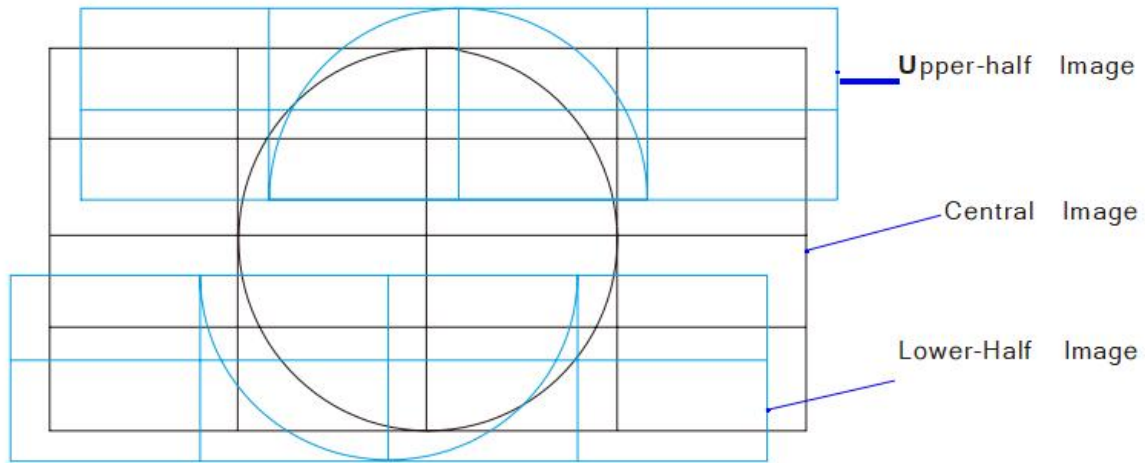

- Adjust the upper-half image to the left so that the upper-half image and the vertical line of the central image completely coincide

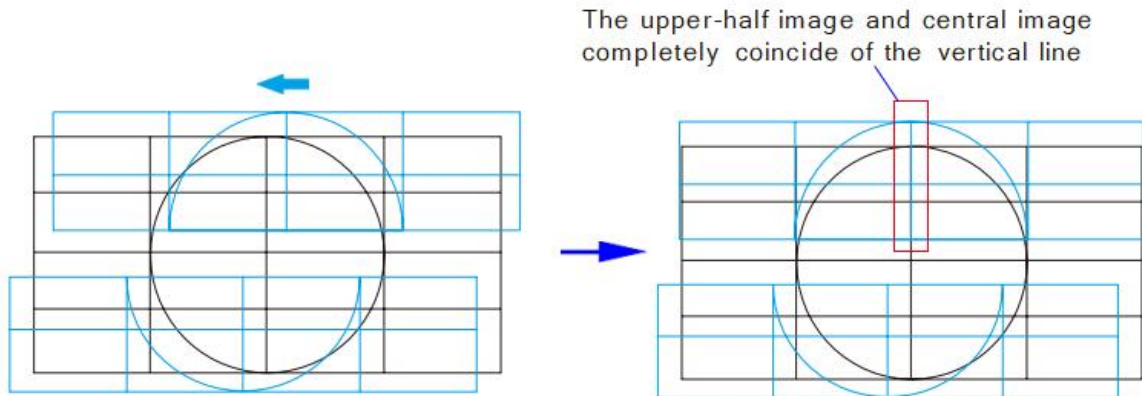

- Adjust the upper-half image downward so that the upper-half image completely coincides with the lower horizontal line of the central image.

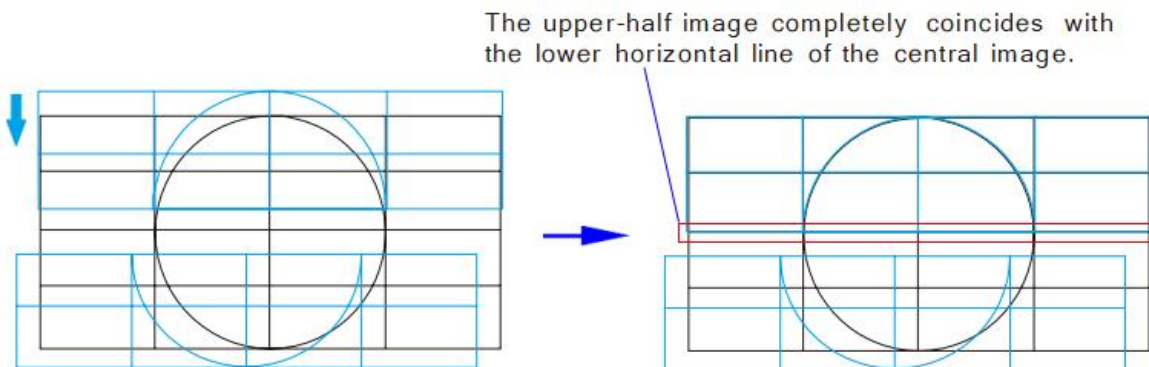

- ③ The same method as before to adjust the Lower-Half Image, first adjust the lower-half image coincide with the central image on the horizontal, then adjust the lower-half image coincide with the central image on the vertical direction

At this time, the upper and lower images are in the middle of the vertical line of the central image, and the middle horizontal lines are completely coincident

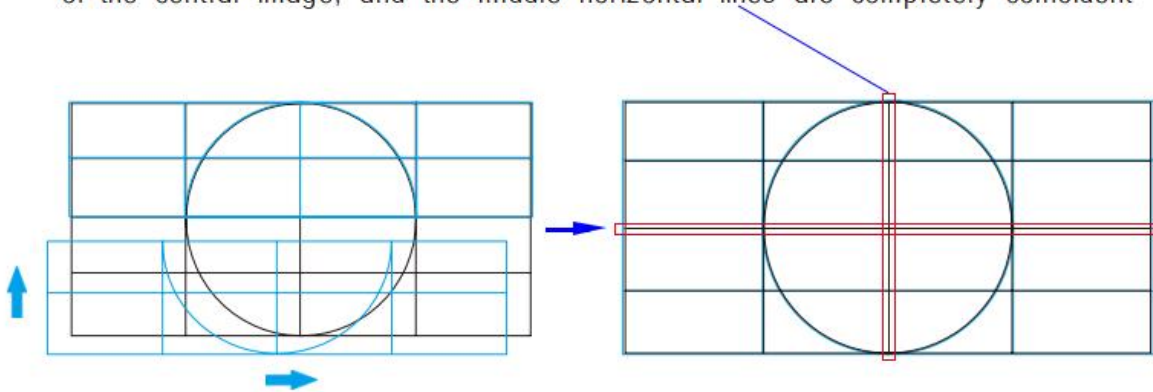

- ④ Adjust the central beam zoom adjustment knob in the optical part until the image is completely coincident

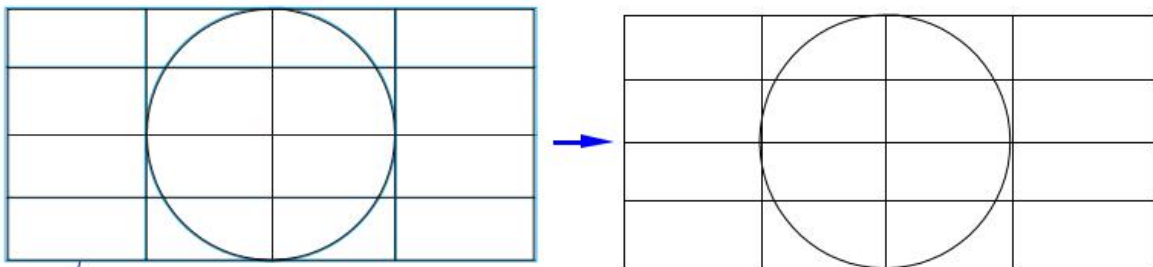

At this time, carefully observe the screen around, you will find that the upper and lower images are slightly larger than the Central image

3D Parameter Setting of cinema projector

©Bacro

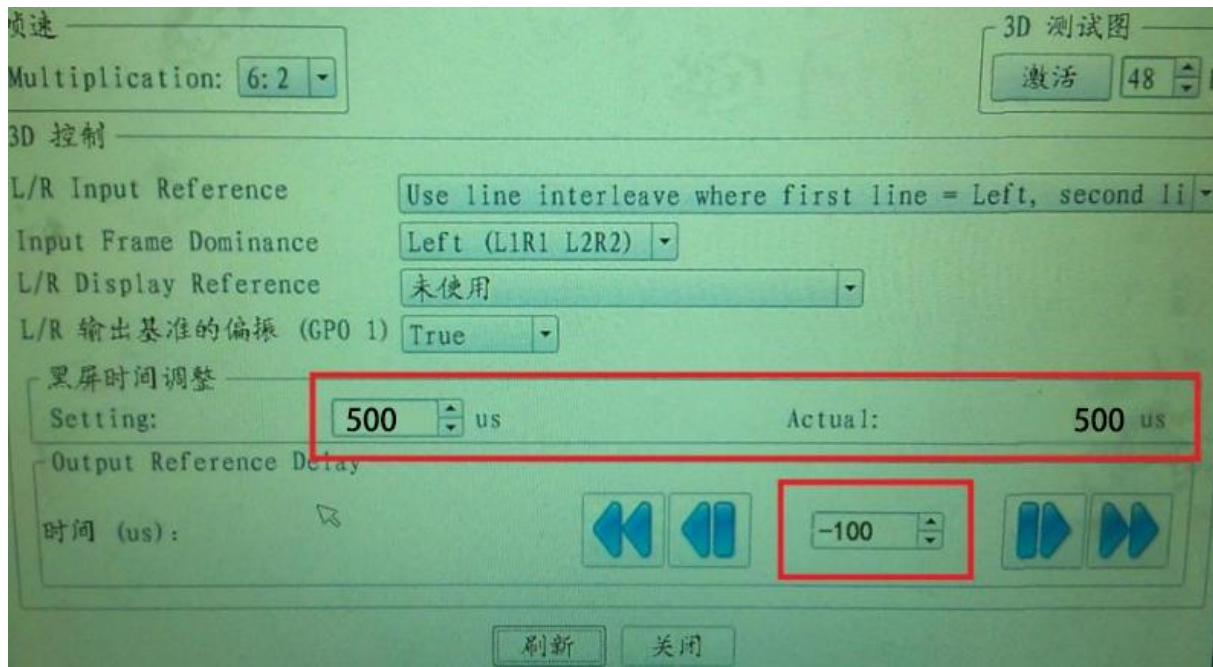

©Christie

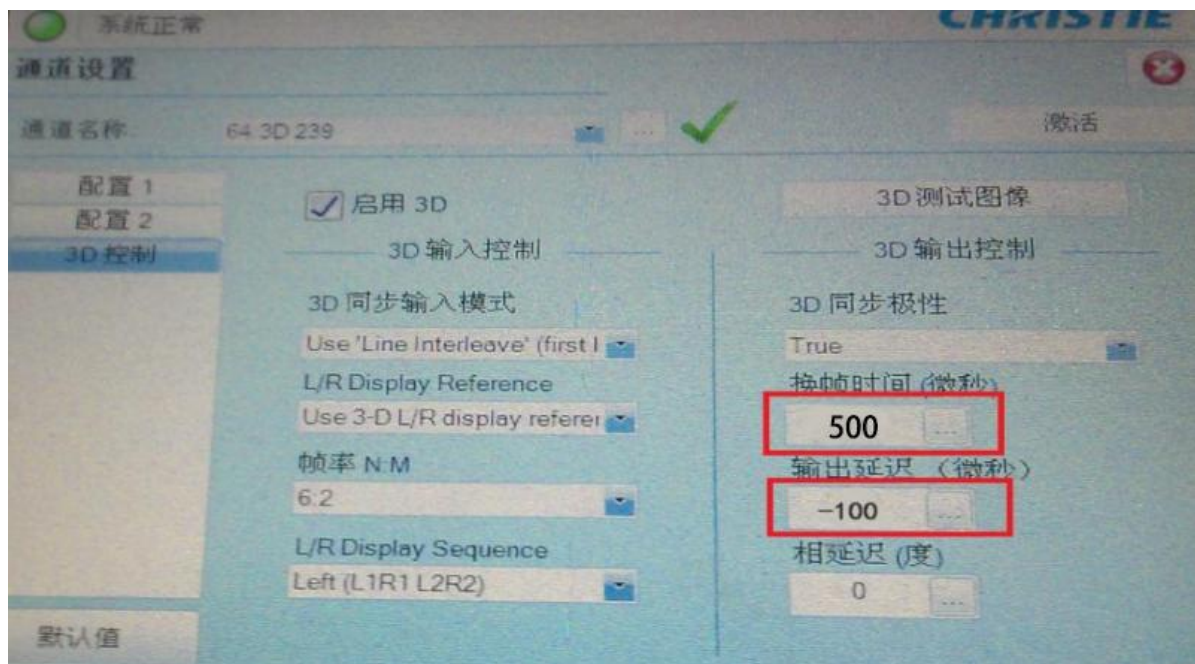

© NEC

3D Controls

3D File Name: Enable_RealD [导入]

Frame Rate Ratio
N : M
6 : 2

3D Control

L/R Input Reference: Use Line Interleave(1st line=Left 2nd line=Right)

Input Frame Dominance: Left (L1R1 L2R2)

L/R Display Reference: Not Used

L/R Output Reference Polarity: true

Dark Time Adjustment 设置: 500 us Actual 500 us

Output Reference Delay 时间: -100 us Phase 0 deg

[另存为] [退出]

Learn more.....

Please contact us!!



Shenzhen Yantuo Electronics Co., Ltd

Facebook: <https://www.facebook.com/Entty.Zou>;

Instagram: https://www.instagram.com/yantok_entty;

Youtube: <https://www.youtube.com/@enttyzeng1972>;

X: <https://x.com/EnttyZeng>;

Whatsapp: <https://wa.me/+8618902843662>;

Email: <mailto:info@yantok.com> ;

Website: <https://en.yantok.com> , <http://www.yantok.com> ;

Addr: Building A, Zhongliantongtai Industrial Zone, No. 271
Liangbai Road, Pinghu Street, Longgang District, Shenzhen,
China.